

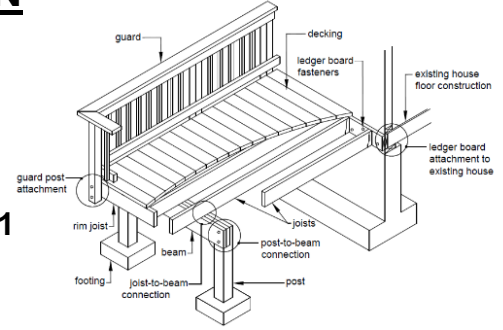

DECK PERMIT APPLICATION

Building Department
25 LaGrange Street
Newnan, GA 30263
Ph. 770-254-2362 Fax 770-254-2361
Email – jcantrell@newnanga.gov



Subject Property

Address: _____
Number and Street Subdivision

Name and Contact #: _____
Name Contact Phone Number

Submission Checklist:

Site plan signed by Planning and Zoning
 (House location plat usually included in your closing documents or obtains from court house)

Plan drawings checklist:

- Overall deck size, include height from grade
- Beam size and spacing
- Ledger board size (show flashing and through bolts)
- Post size and location
- Footing size, depth, and connection
- Joist size and spacing
- Joist connections (hangers)
- Size of decking
- Size and spacing of guardrail posts
- Size and spacing of pickets
- Height of guardrail
- Stair location and pad
- Cantilever if applicable

Inspections

- Footing – before concrete is placed
- Framing – before decking is installed (only if deck is less than 3 feet from grade)
- Final – after entire deck is completed

Estimated cost of project: _____ Square Footage: _____

I understand that I am to phone in all inspections for this project, and will be responsible for complying with all construction codes as adopted by the State of Georgia DCA.

 Signature of Owner Occupant Date

